

H₂O COIL

ASH **ALLSTYLE** HORIZONTAL COILS

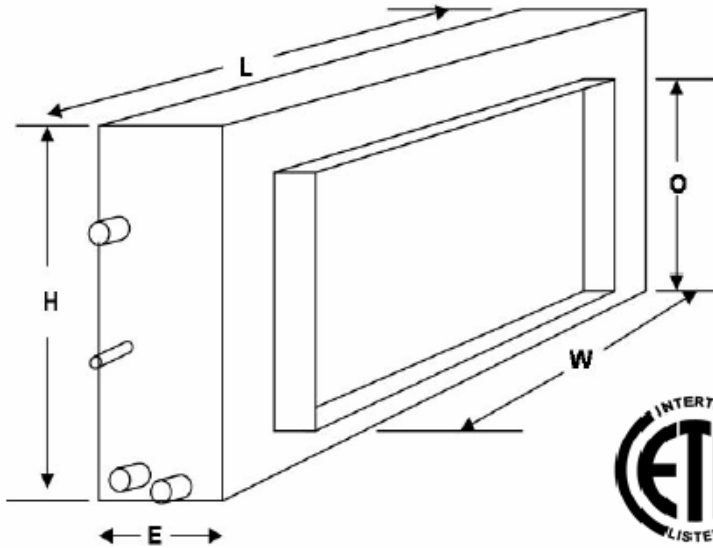

Standard Residential Features:

- Embossed galvanized steel case
- Heavy rifled copper tubing
- Aluminum fins
- Heavy aluminum end plates to reduce corrosion
- Pressure tested to 450 lbs.
- Dual rated for R-22 and R-410a
- Standard polymer drain pan
- Insulated cabinet with no exposed fiberglass insulation

Standard Commercial Features:

- Bi-Directional airflow
- Embossed galvanized cabinet
- Single stage circuiting standard
- Expansion valve refrigerant control
- Engineered polymer drain pan
- Optional dual circuiting available

5-year limited warranty against coil leakage and drain pan failure. 1-year functional parts warranty.

3/4" MPT drain connections
 3/8" liquid line on 1.5 to 5.0 tons
 1/2" liquid line on 8.0 to 10.0 tons

Suction line connections:

3/4" on 1.5 to 3.0 tons
 7/8" on 3.5 to 5.0 tons
 1 1/8" on 8.0 tons
 1 3/8" on 10.0 tons



RESIDENTIAL HORIZONTAL COIL DIMENSIONS

Coil	Cabinet Length L	Cabinet Width E	Cabinet Height H	Plenum Length W	Plenum Height O
ASH24-L2C-5	22.00"	10.00"	24.50"	16.00"	21.00"
ASH30-L4C-5B	24.30"	10.00"	24.50"	16.00"	21.00"
ASH36-Q4C-6	30.00"	10.00"	24.50"	24.00"	21.00"
ASH42-Q2TC-6	30.00"	10.00"	24.50"	24.00"	21.00"
ASH48-A4C-7	36.00"	10.00"	24.50"	30.00"	21.00"
ASH60-AZO-7B	37.00"	10.00"	24.50"	34.00"	21.00"

COMMERCIAL HORIZONTAL COIL DIMENSIONS

Coil	Cabinet Length L	Cabinet Width E	Cabinet Height H	Plenum Length W	Plenum Height O
ASH-96X	45.00"	16.00"	24.50"	36.00"	21.00"
ASH-120X	45.00"	16.00"	36.50"	36.00"	33.00"

H₂O COIL INC.

3514 HARGALE RD. OCEANSIDE, NY 11572 TEL: (516) 256-3131 FAX: (516) 599-2000