

H₂O COIL

ATQ Series - 1-Row Hot Water Duct Coils

In STOCK

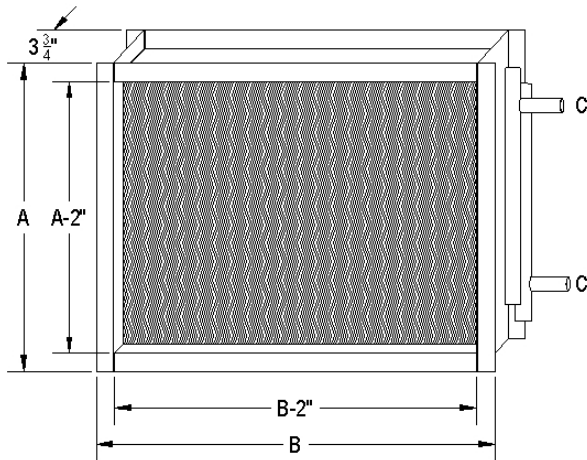

- ARI 410 Certified
- Galvanized Steel 18GA frame
- Aluminum Fins, .0045 thickness
- Copper Tubing, 1/2" w/ .016 wall
- Max 500 PSI Operating Pressure
- Max 2500 PSI Ultimate Pressure
- BTU outputs from 30,000 to 140,000
- Horizontal/Vertical Installation
- Full one year warranty

Part #	GPM	CFM	BTUH	APD	A	B	C
ATQ1-0712	4	300	10,010	.07	9.5	14	7/8
		400	11,410	.12			
		500	12,560	.18			
ATQ1-1212	4	600	17,843	.10	14.5	14	7/8
		700	19,085	.13			
		800	20,188	.16			
ATQ1-1218	4	900	26,215	.10	14.5	20	7/8
		1000	27,427	.12			
		1100	28,543	.14			
ATQ1-1224	4	1400	36,515	.13	14.5	26	7/8
		1500	37,548	.15			
		1600	38,523	.16			
ATQ1-1515	4	1000	27,427	.12	17	17	7/8
		1100	28,543	.14			
		1200	29,575	.16			
ATQ1-1520	4	1300	34,111	.11	17	22	7/8
		1400	35,128	.13			
		1500	36,082	.15			
ATQ1-1524	4	1600	40,666	.12	17	26	7/8
		1700	41,632	.13			
		1800	42,547	.15			
ATQ1-1530	4	2000	49,592	.12	17	32	7/8
		2100	50,513	.13			
		2200	51,395	.14			

Part #	GPM	CFM	BTUH	APD	A	B	C
ATQ1-1536	4	2500	58,953	.13	17	38	7/8
		2600	59,978	.14			
		2700	60,613	.15			
ATQ1-1718	4	1400	34,866	.12	19.5	20	7/8
		1500	35,790	.14			
		1600	36,657	.15			
ATQ1-1724	4	1900	45,488	.12	19.5	26	7/8
		2000	46,350	.14			
		2100	47,172	.15			
ATQ1-1730	4	2400	55,493	.13	19.5	32	7/8
		2500	56,301	.14			
		2700	57,825	.15			
ATQ1-1736	4	2800	64,137	.12	19.5	38	7/8
		3000	65,680	.14			
		3200	67,123	.15			
ATQ1-1742	4	3500	74,523	.14	19.5	44	7/8
		3600	75,216	.14			
		3700	75,888	.15			
ATQ1-2036	4	3700	73,013	.15	22	38	1-1/8
		3800	73,622	.16			
		4000	74,790	.18			

Performance data based on 65° EAT, 180° EWT

H₂O COIL

ATQ Series - 2-Row Hot Water Duct Coils

In STOCK

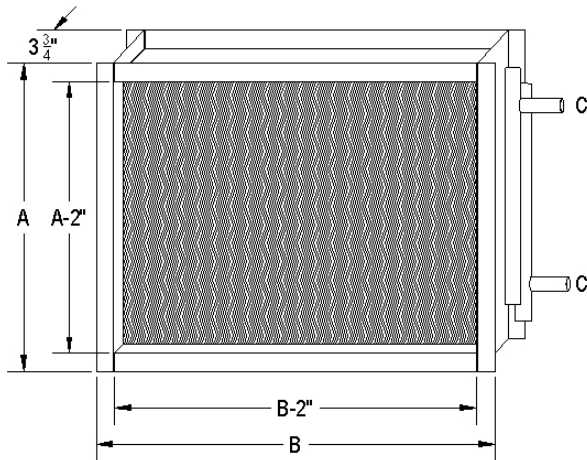

- ARI 410 Certified
- Galvanized Steel 18GA frame
- Aluminum Fins, .0045 thickness.
- Copper Tubing, 1/2" w/ .016 wall
- Max 500 PSI Operating Pressure
- Max 2500 PSI Ultimate Pressure
- BTU outputs from 20,000 to 140,000
- Horizontal/Vertical Installation
- Full one year warranty

Part #	GPM	CFM	BTUH	APD	A	B	C
ATQ2-0712	4	400	19,780	.26	9.5	14	7/8
ATQ2-1024	7.2	1000	42,328	.23	12	26	7/8
ATQ2-1212					14	14	7/8
ATQ2-1215	7.2	700	38,403	.19	14.5	17	7/8
		800	41,286	.24			
		900	43,911	.29			
ATQ2-1218	7.2	900	47,361	.22	14.5	20	7/8
		1000	50,069	.26			
		1100	52,577	.30			
ATQ2-1224	7.2	1000	56,077	.16	14.5	26	7/8
		1200	61,858	.22			
		1400	66,941	.28			
ATQ2-1236	7.2	1200	75,874	.14	14.5	38	7/8
		1400	81,261	.18			
		1600	86,119	.22			
ATQ2-1515	7.2	800	42,974	.18	17	17	7/8
		900	45,714	.22			
		1000	48,225	.26			
ATQ2-1518	7.2	1000	52,090	.19	17	20	7/8
		1100	54,704	.22			
		1200	57,133	.26			
ATQ2-1520	7.2	1200	59,737	.22	17	22	7/8
		1300	62,167	.25			
		1400	64,448	.28			

Part #	GPM	CFM	BTUH	APD	A	B	C
ATQ2-1524	7.2	1400	69,565	.21	17	26	7/8
		1500	71,982	.23			
		1600	74,267	.26			
ATQ2-1530	7.2	1600	81,261	.18	17	32	7/8
		1800	86,119	.22			
		2000	90,535	.26			
ATQ2-1536	7.2	2000	97,307	.19	17	38	7/8
		2300	103,943	.24			
		2600	109,843	.30			
ATQ2-1718	7.2	1200	60,949	.20	19.5	20	7/8
		1300	63,457	.23			
		1400	65,811	.26			
ATQ2-1724	7.2	1500	76,579	.18	19.5	26	1-1/8
		1700	81,481	.22			
		1900	85,915	.27			
ATQ2-1730	7.2	2000	92,337	.20	19.5	32	1-1/8
		2200	96,397	.23			
		2400	100,127	.27			
ATQ2-1736	10.0	2500	118,120	.21	19.5	38	1-1/8
		2700	122,465	.24			
		2900	126,533	.27			
ATQ2-1742	10.0	2700	130,323	.19	19.5	44	1-1/8
		3300	136,936	.22			
		3300	142,978	.26			

Performance data based on 65° EAT, 180° EWT

H₂O COIL

ATQ Series - 2 & 3-Row Hot Water Duct Coils

In STOCK

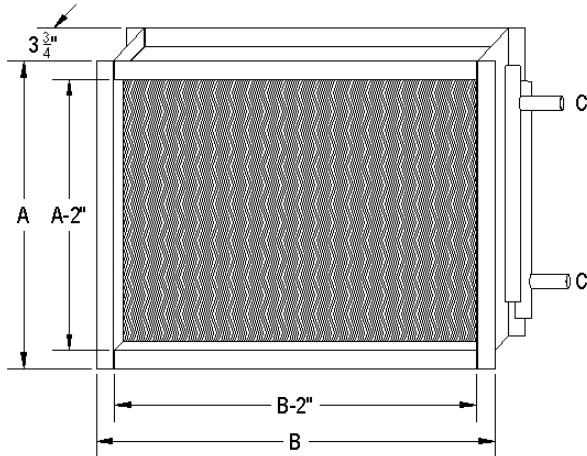

- ARI 410 Certified
- Galvanized Steel 18GA frame
- Aluminum Fins, .0045 thickness.
- Copper Tubing, 1/2" w/ .016 wall
- Max 500 PSI Operating Pressure
- Max 2500 PSI Ultimate Pressure
- BTU outputs from 70,000 to 140,000
- Horizontal/Vertical Installation
- Full one year warranty

Part #	GPM	CFM	BTUH	APD	A	B	C
ATQ2-2020	7.2	1600	73,270	.22	22	22	7/8
		1700	75,320	.24			
		1800	77,260	.26			
ATQ2-2025	7.2	1900	87,264	.20	22	27	7/8
		2100	91,268	.24			
		2300	94,929	.27			
ATQ2-2324	7.2	2000	94,330	.17	25.75	26	1 1/8
		2300	100,450	.22			
		2600	105,850	.27			
ATQ2-2525	7.2	2200	102,270	.18	27	27	1 1/8
		2600	110,008	.23			
		3000	116,800	.29			
ATQ2-2030	10.0	2400	112,376	.22	22	32	1 1/8
		2600	116,641	.25			
		2800	120,622	.28			
ATQ2-2036	10.0	2800	130,192	.21	22	38	1 1/8
		3000	134,385	.23			
		3200	138,331	.26			

Part #	GPM	CFM	BTUH	APD	A	B	C
ATQ3-1215	7.2	500	40,230	.17	14.5	17	7/8
		600	45,220	.22			
		700	49,672	.29			
ATQ3-1520	7.2	800	61,010	.17	17	22	7/8
		950	67,520	.22			
		1100	73,390	.28			
ATQ3-2020	7.2	1000	75,348	.15	22	22	7/8
		1200	83,675	.20			
		1400	90,935	.26			
ATQ3-2025	7.2	1600	105,890	.22	22	27	7/8
		1725	110,070	.25			
		1850	113,989	.29			
ATQ3-2030	10.0	1800	127,560	.20	27	27	7/8
		2000	135,230	.24			
		2200	142,280	.28			
ATQ3-2525	10.0	1800	129,332	.19	27	27	7/8
		2000	137,179	.22			
		2200	144,395	.26			

Performance data based on 65° EAT, 180° EWT

H₂O COIL

ATQ Series - Commercial 2-Row Hot Water Duct Coils

In STOCK

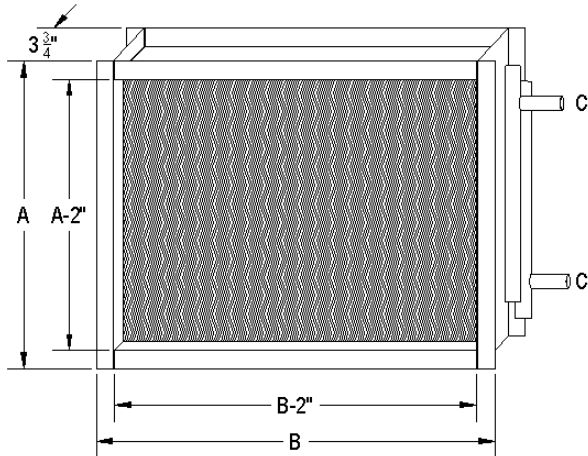

- ARI 410 Certified
- Galvanized Steel 18GA frame
- Aluminum Fins, .0045 thickness
- Copper Tubing, 1/2" w/ .016 wall
- Max 500 PSI Operating Pressure
- Max 2500 PSI Ultimate Pressure
- BTU outputs from 160,000 to 360,000
- Horizontal/Vertical Installation
- Full one year warranty

Part #	GPM	CFM	BTUH	APD	A	B	C
ATQ2-2336	18	2600	164,634	.16	26	38	1-3/8
		2800	171,100	.18			
		3000	177,189	.21			
		3200	182,938	.23			
		3400	188,381	.25			
ATQ2-2348	20	3600	221,767	.17	26	50	1-3/8
		3800	227,960	.19			
		4000	233,881	.21			
		4400	244,982	.24			
		4800	255,212	.28			
ATQ2-3054	24	5200	315,553	.18	32	56	1-5/8
		5600	327,467	.20			
		6000	338,674	.23			
		6400	349,229	.25			
		6800	359,196	.28			

Performance data based on 60° EAT, 180° EWT